



# Environmental Accounts

## Economy-wide Material flow accounts and their extension to circular flows

Dr. Florian Kohler, FSO

Material and energy flow analysis - EPFL

18.09.2025



# Content

- Environmental accounts at FSO
- Material flows accounts
- Circular material use

# Environmental accounts at FSO

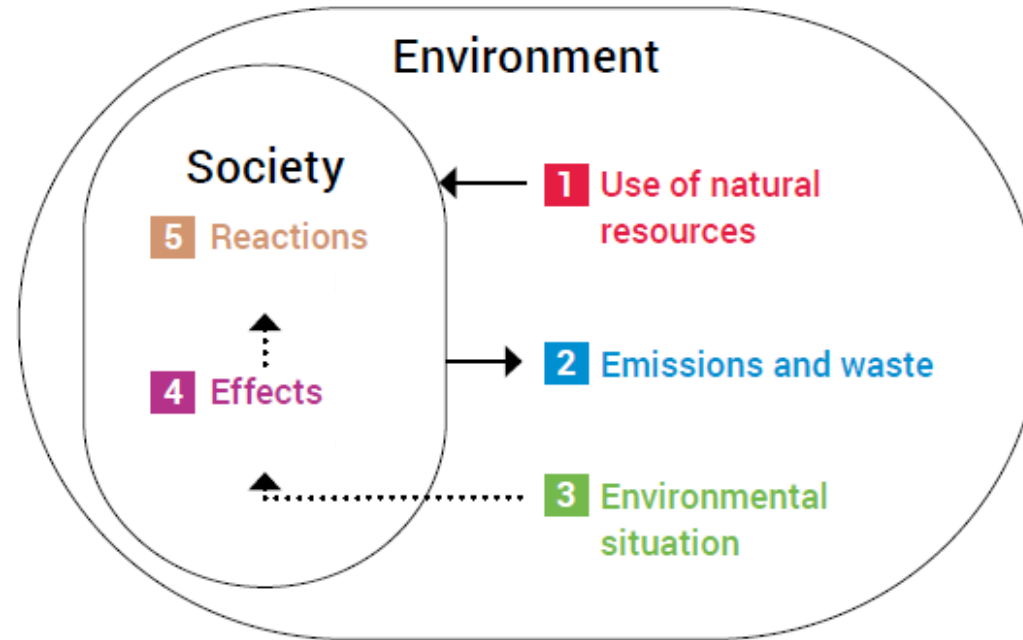

# Fundamental purpose

## **Statement**

Increasing interactions between the economy and the environment

## **Needs**

To have integrated and comparable environmental and economic statistics for powerful analysis

## **Difficulty**

Environmental and economic statistics are very frequently not comparable because of use of different definitions and classifications

## **Solution**

To adjust the environmental statistics to the principles, definitions and classifications of the National accounts / economic statistics

→ **Environmental accounts**

# Principles

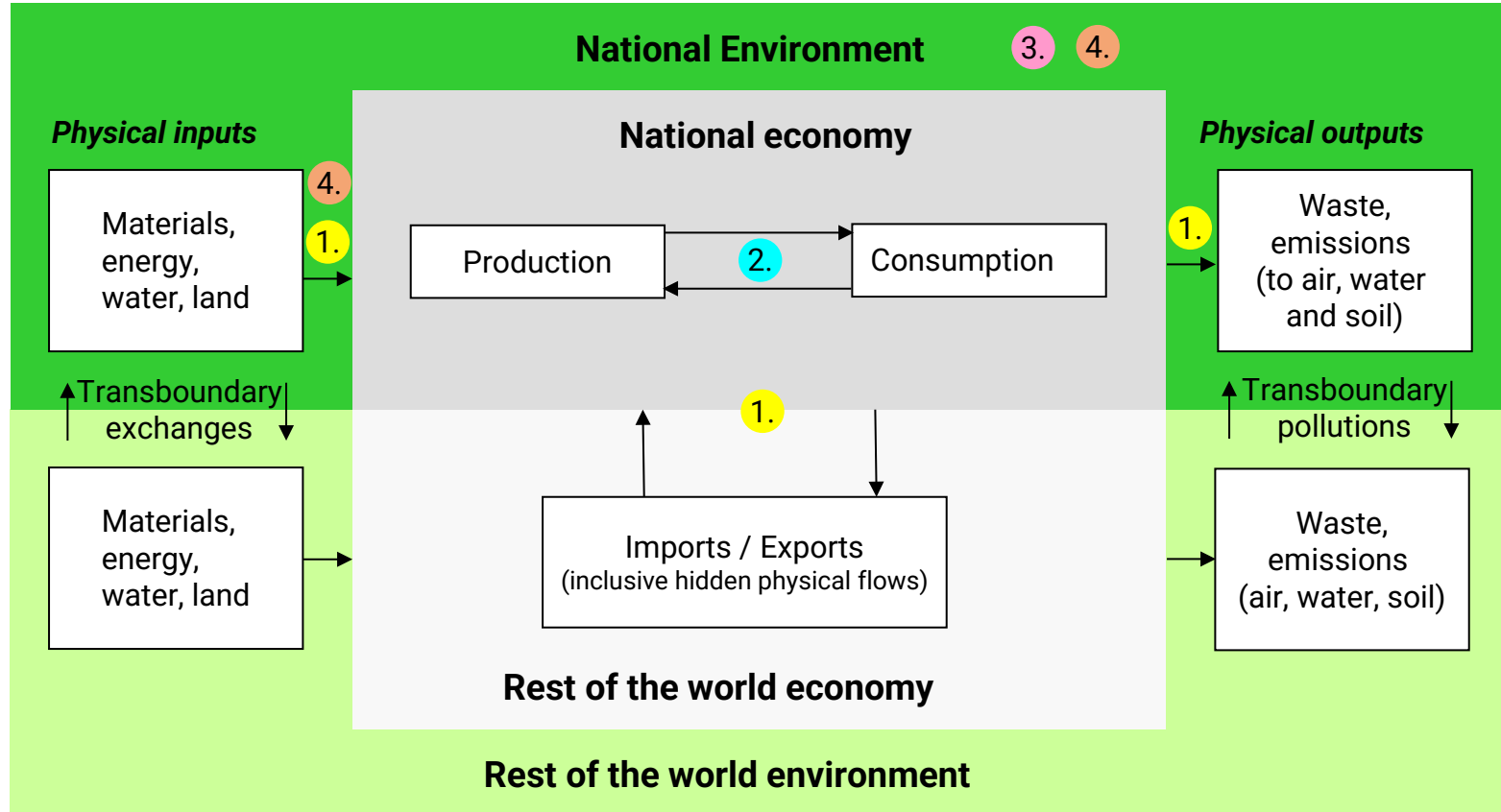

1. Physical flow accounts

2. Monetary flow accounts

3. Asset accounts for natural resources

4. Ecosystem accounts

# Position in the statistical system

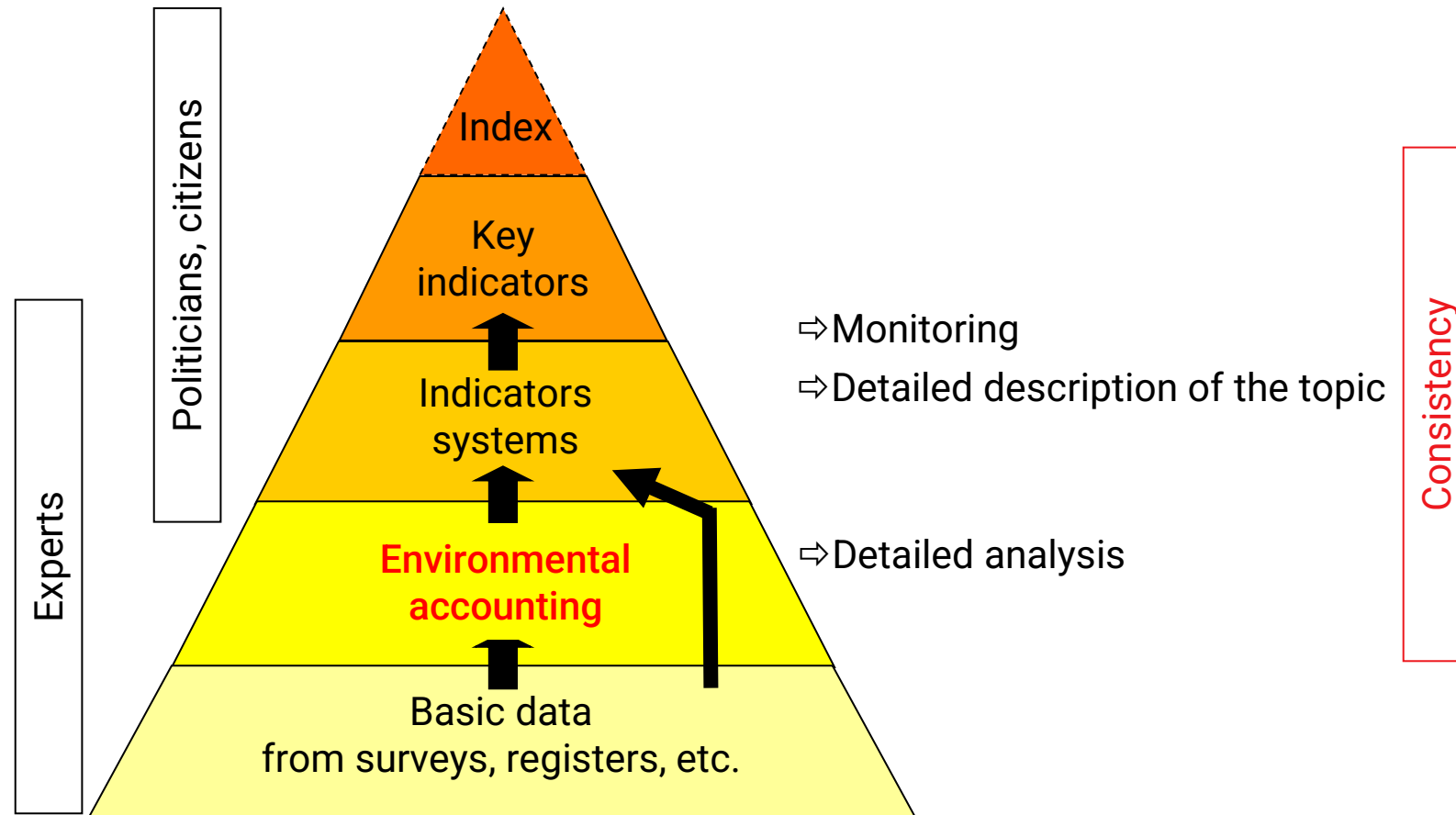

# Developments at UNO

## System of Environmental and Economic Accounting 2012 The international statistical standard

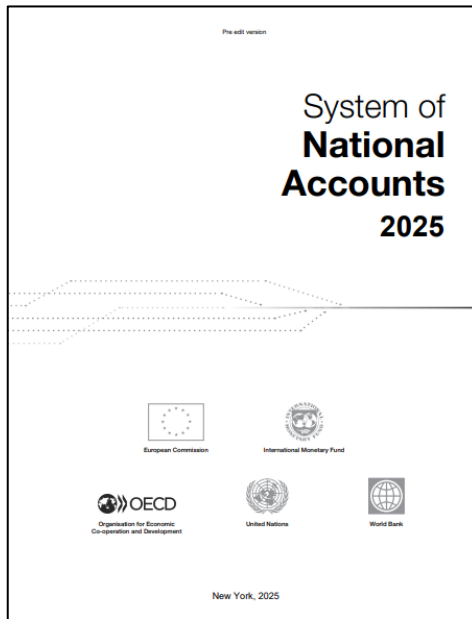

← Counterpart →



<https://seea.un.org/>



adopted by the UN  
Statistical Commission in  
March 2021

# Developments at UNO

## Countries involvement in 2024

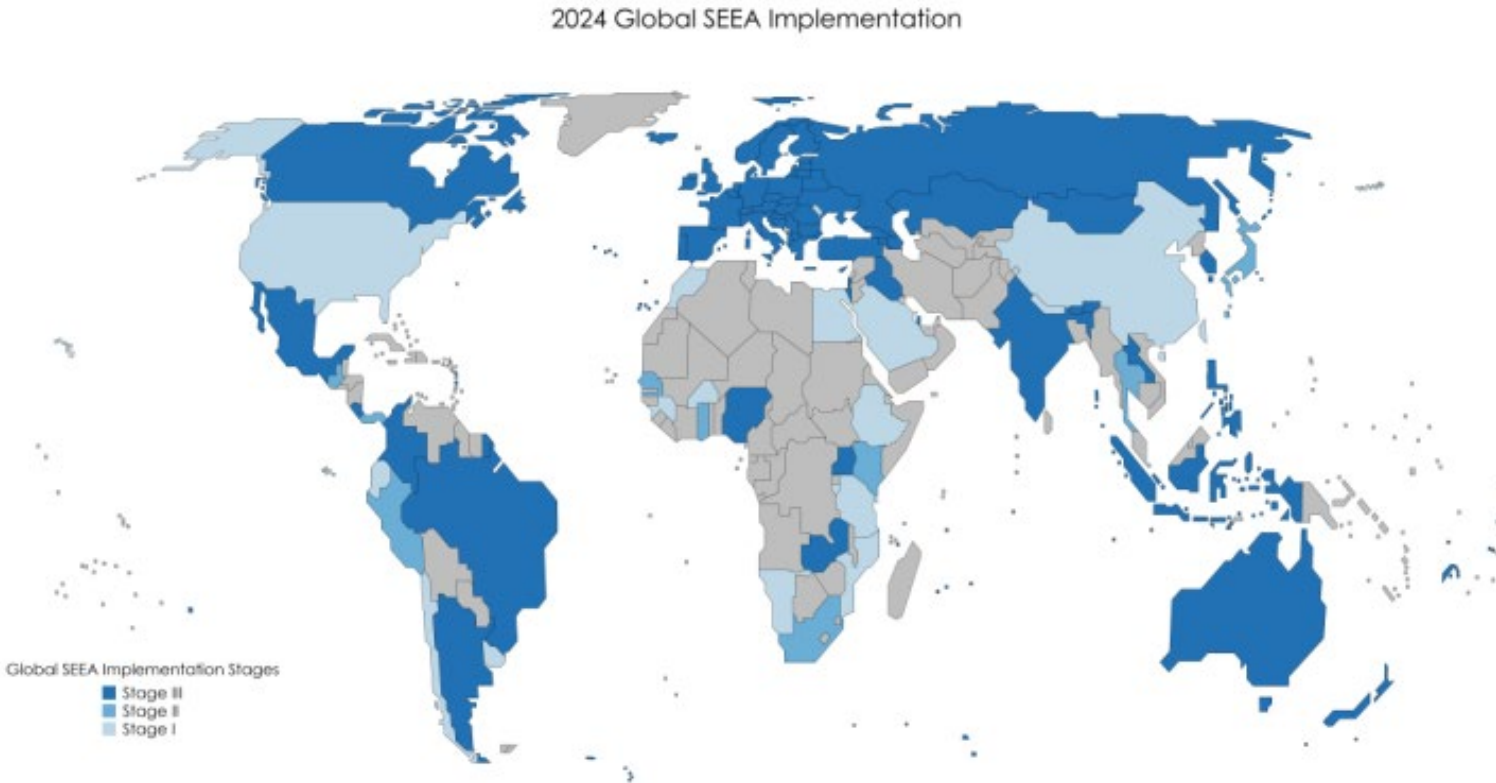

94 countries:

- 67 publish at least one account on a regular basis (**stage III**)
- 10 publish their accounts on an ad-hoc basis (**stage II**)
- 17 compile, but do not yet publish their accounts (**stage I**)

<https://seea.un.org/>

# Current stage at European level



## The legal base 691/2011

- EW-MFA - Economy-wide Material Flow Accounts (since 2011)
- AEA - Air Emission Accounts (since 2011)
- TAX - Environmental Taxes by economic activity (since 2011)
- EPEA - Environmental Protection Expenditure Accounts (since 2014)
- EGSS - Environmental Goods and Services Sector accounts (since 2014)
- PEFA - Physical Energy Flow Accounts (since 2014)

## and since 1.1.2025, three new modules

- Environmental subsidies accounts
- Forest accounts
- Ecosystem accounts

# Environmental accounts at FSO

The **monetary flow accounts** provide information on financial transactions related to the environment

- Environmental protection expenditure
- Environmental taxes
- Environmental goods and services sector
- Environmental subsidies and other transfers

The **physical flow accounts** provide information on the physical flows, which run through the economy

- Air Emissions Accounts
- Physical Energy Flow Accounts
- Economy-wide Material Flow Accounts
- Water accounts (pilot study ends in 2025)

# Environmental accounts at FSO

The **asset accounts for natural resources** provide information on the stocks of natural resources and their variations

- EFA – European Forest Accounts

The **ecosystem accounts** constitutes an integrated and comprehensive statistical framework for organizing data about habitats and landscapes, measuring the ecosystem services, tracking changes in ecosystem assets, and linking this information to economic and other human activity

- Pilot study completed (focus on Forest ecosystems and Carbon sequestration)
- Step-by-step implementation in preparation

# Environmental taxes

## Environmentally related taxes revenue

By economic player

CHF billion, at current prices

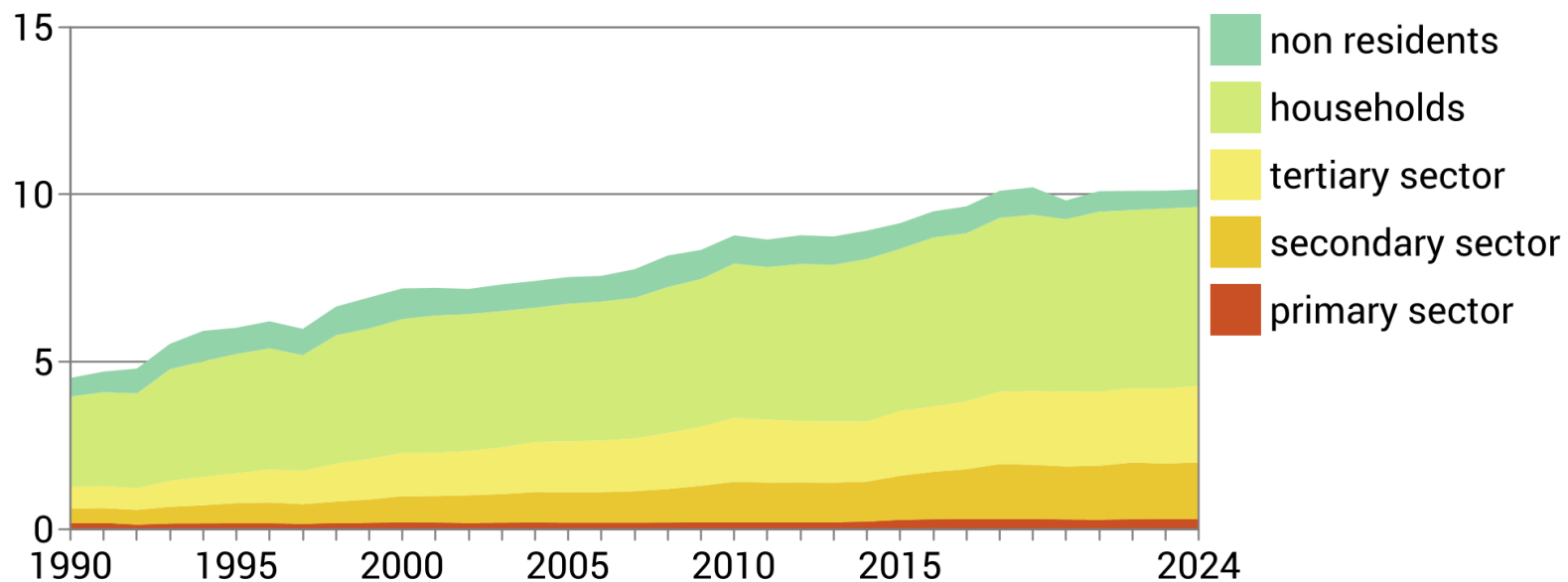

2023: provisional, 2024: estimates

Source: FSO – Environmental accounting

© FSO 2025

# Environmental goods and services sector

## Employees of the environmental sector by domain

Thousand full time equivalents

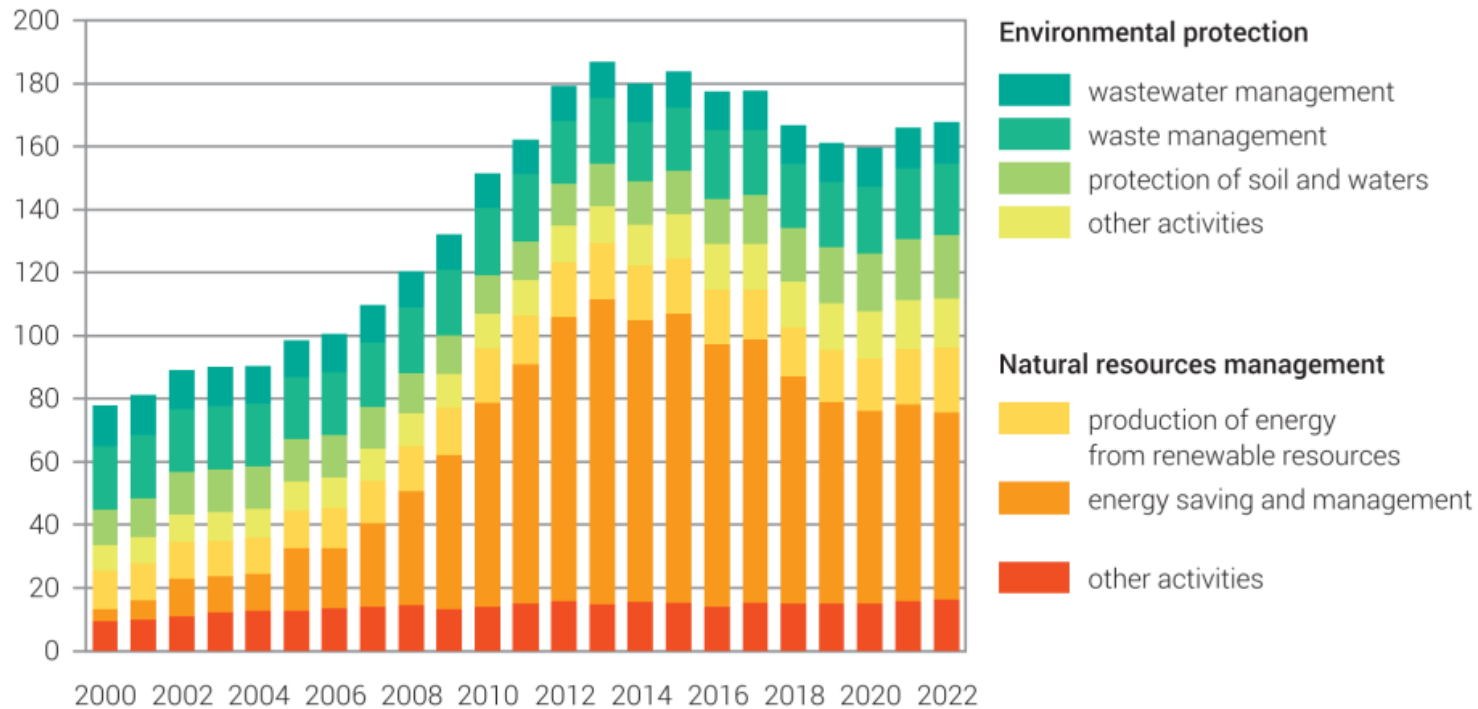

2022: provisional

Source: FSO – Environmental accounting

© FSO 2023

# Air Emissions Accounts

## Greenhouse gas emissions by economic player

Million tonnes of CO2 equivalent, inclusive CO2 from biomass combustion

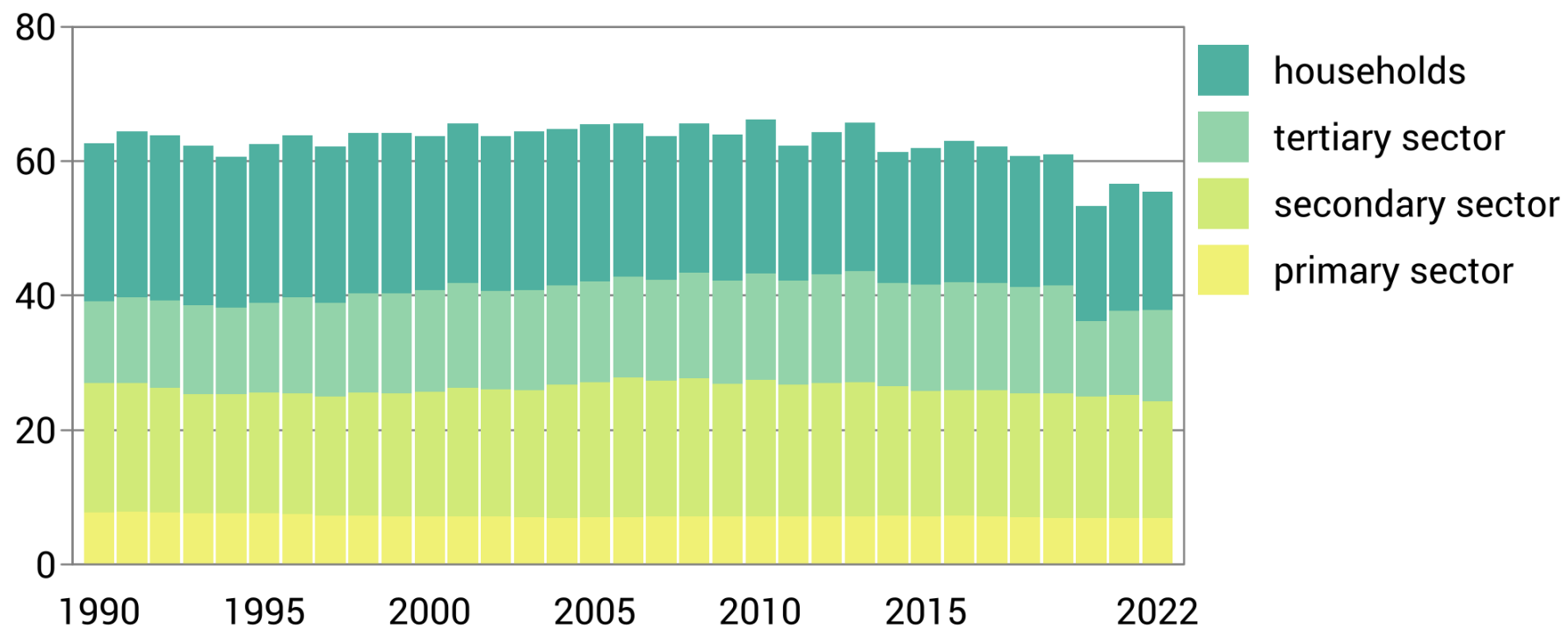

Source: FSO – Environmental accounting

© FSO 2024

# Air Emissions Accounts

## Greenhouse gas footprint

Greenhouse gas emissions due to final domestic demand

Million tonnes of CO2 equivalent

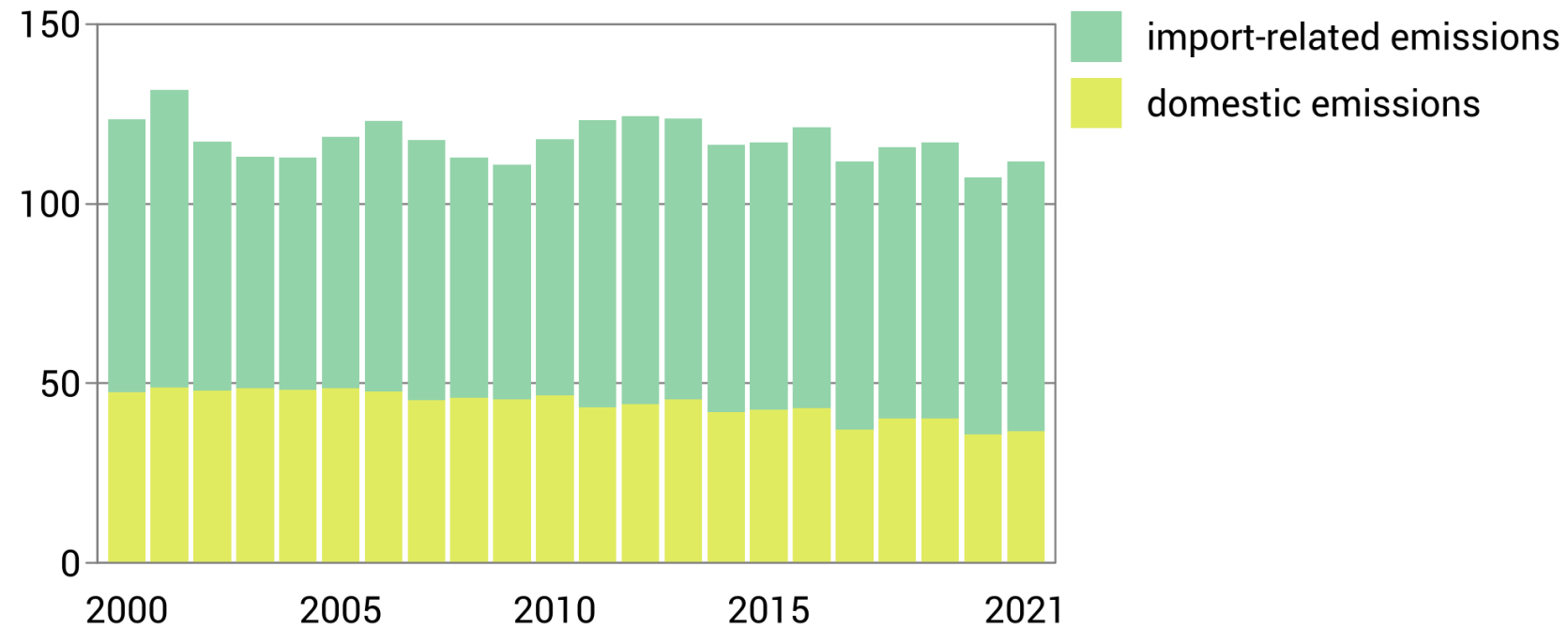

Source: FSO – Environmental accounting

© FSO 2023

# Physical Energy Flow Accounts

## Energy use by economic activity, 2022

### Percent of total energy use of the economy

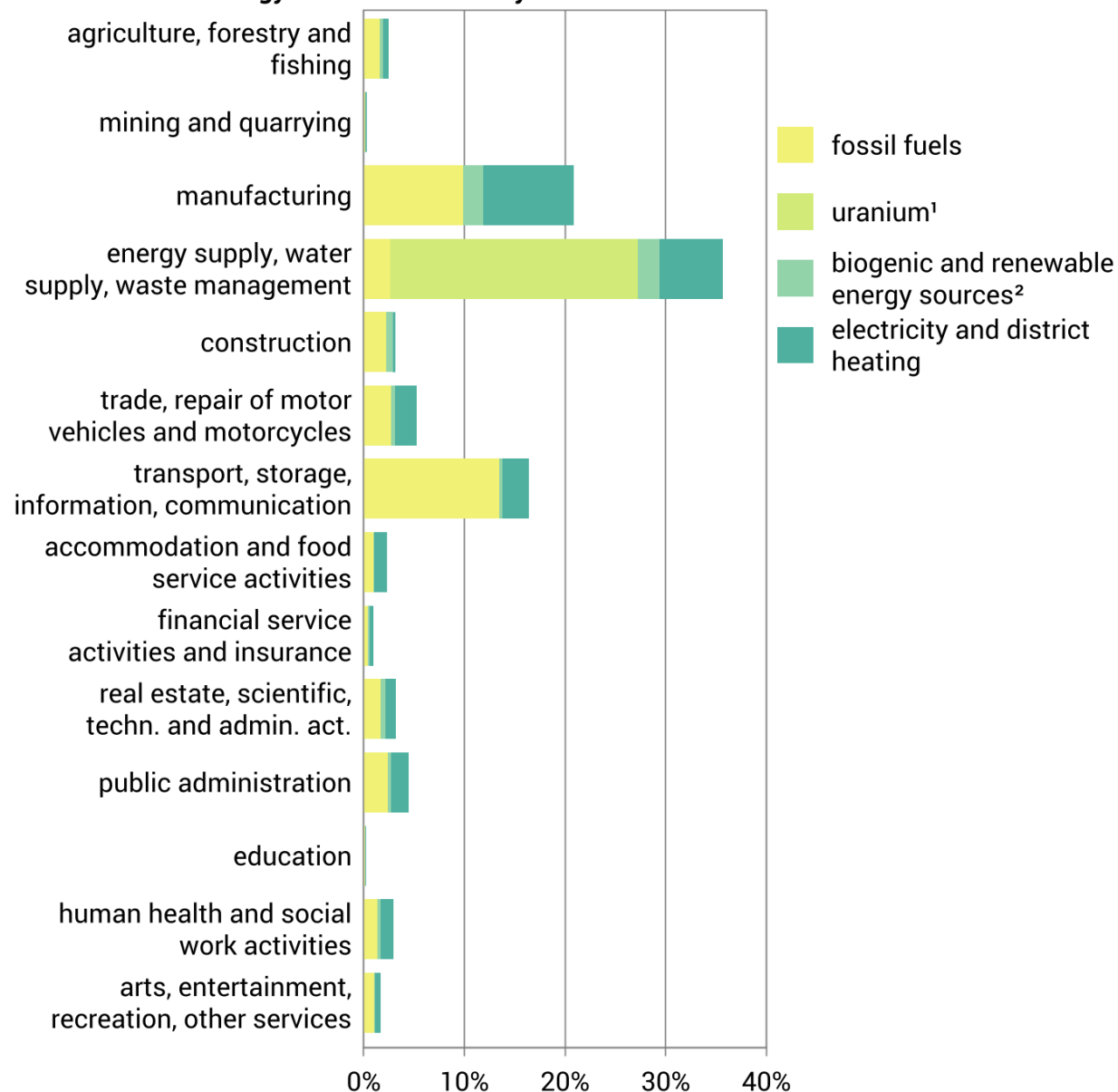

<sup>1</sup> transformation losses of nuclear energy to electricity and district heating

<sup>2</sup> hydraulic, wind and solar energy transformed in electricity is accounted in electricity

# Forest accounts - standing timber in Swiss forests

## Stock économique de bois sur pied

A prix courants, en millions de francs

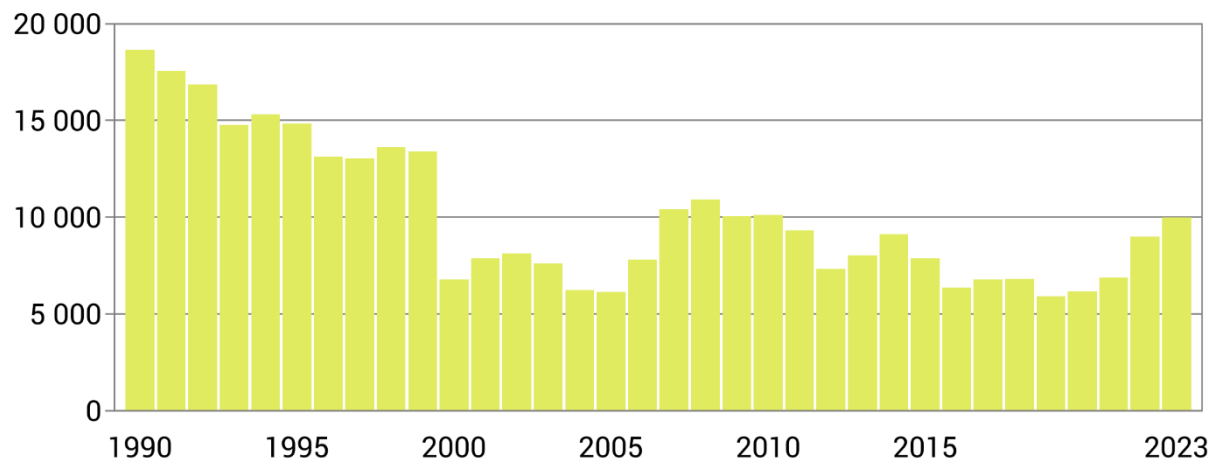

2022 provisoire, 2023 estimation

Source: OFS – Comptes économiques de la sylviculture

© OFS 2024

## Stock de bois sur pied

Volume en écorce, en millions de m<sup>3</sup>

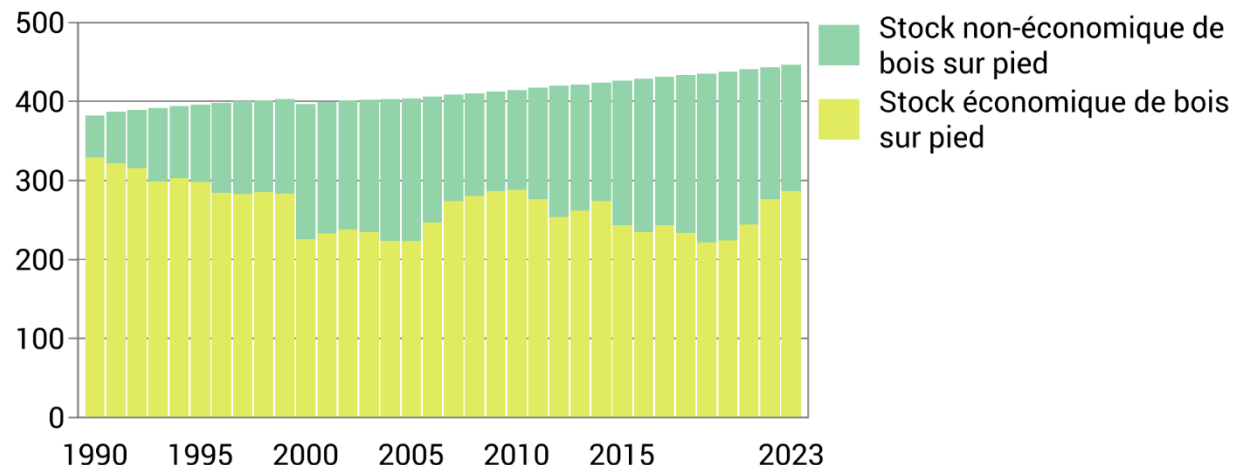

2022 provisoire, 2023 estimation

Source: OFS – Comptes économiques de la sylviculture

© OFS 2024

# Economy-wide Material Flow Accounts EW-MFA



# International context

- Eurostat and OECD play a key role
- In 2007, 2009 and 2011, questionnaires were filled by countries (inclusive CH) under gentlemen agreements
- Since 2013 EU member states have to deliver yearly data to Eurostat (Legal base 691/2011)
- Indicators are used in numerous international reports on the environment and sustainable development (SDGs)

# EW-MFA - Concept

## Objective

To measure, in tonnes and yearly, material flow which passes through the economy (inclusive households)

## System boundaries

- by the extraction of primary (i.e., raw, crude or virgin) materials from the national environment and the discharge of materials to the national environment
- by the political (administrative) borders that determine material flows to and from the rest of the world (imports and exports)
- only flows which cross these boundaries are taken into account ☒ the economy is considered as a black box

# EW-MFA – Overview

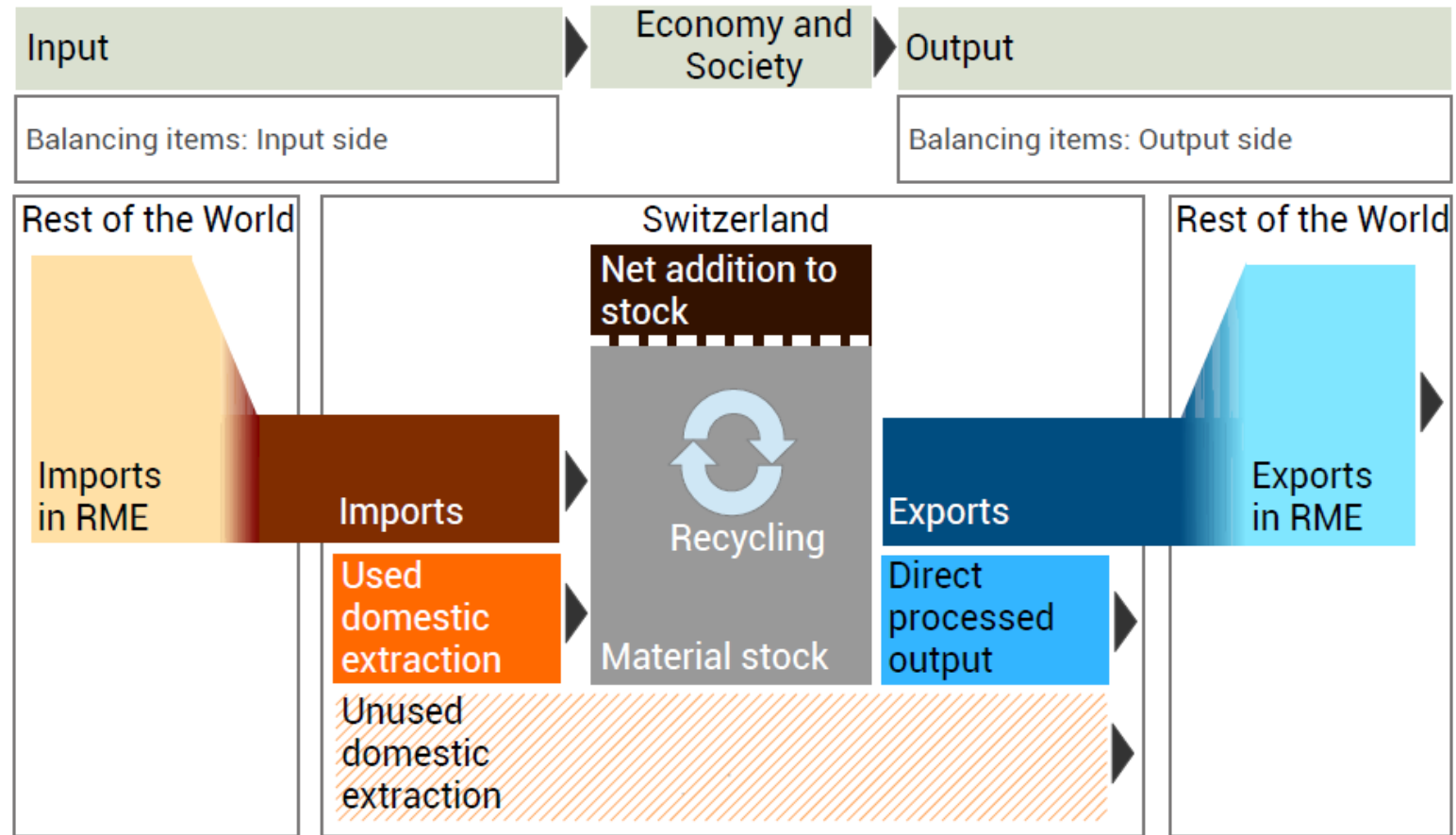

RME : Raw material equivalents

# EW-MFA – Methodological approach

Production of such a statistic depends on a high number of basic statistics

- Economical Accounts for Agriculture EAA
- Economical Accounts for Forestry
- Livestocks and crop area statistics
- Foreign trade statistics
- Energy statistics
- Fishery and Hunting Statistics
- UNFCCC-greenhouse gas emission inventory
- CLRTAP-air pollutants inventory
- Air Emissions Accounts
- Waste statistics
- Industries annual reports
- Estimates for lacking information
- ...

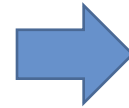

- find the best data source
- gather data in the same database
- harmonize and adjust to the system boundaries
- follow closely if new data sources appear

# Trade in Raw material equivalent

- The RME flows represent the total mass of raw material extracted for the production and transport of goods and services until they cross the border.
- The RME indicators are the result of modelling and are less reliable than the indicators of direct flows.

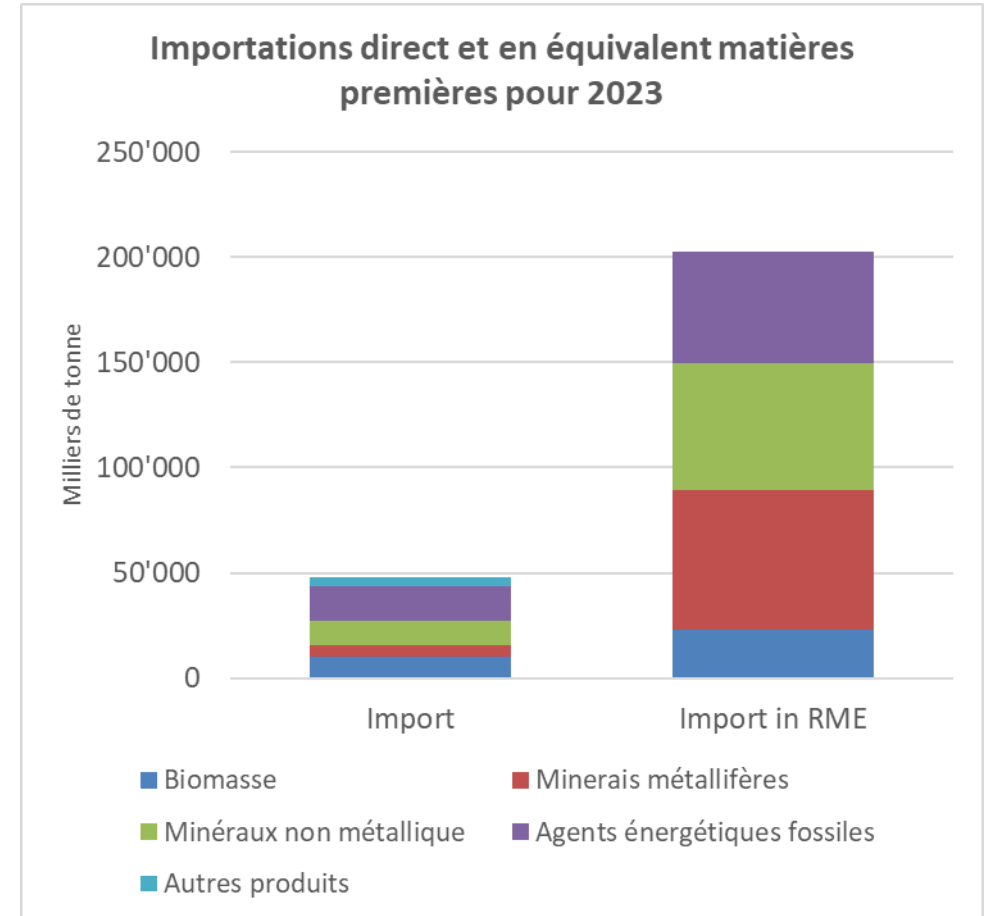

# Indicators

Figure 1: Scheme for EW-MFA and derived Indicators

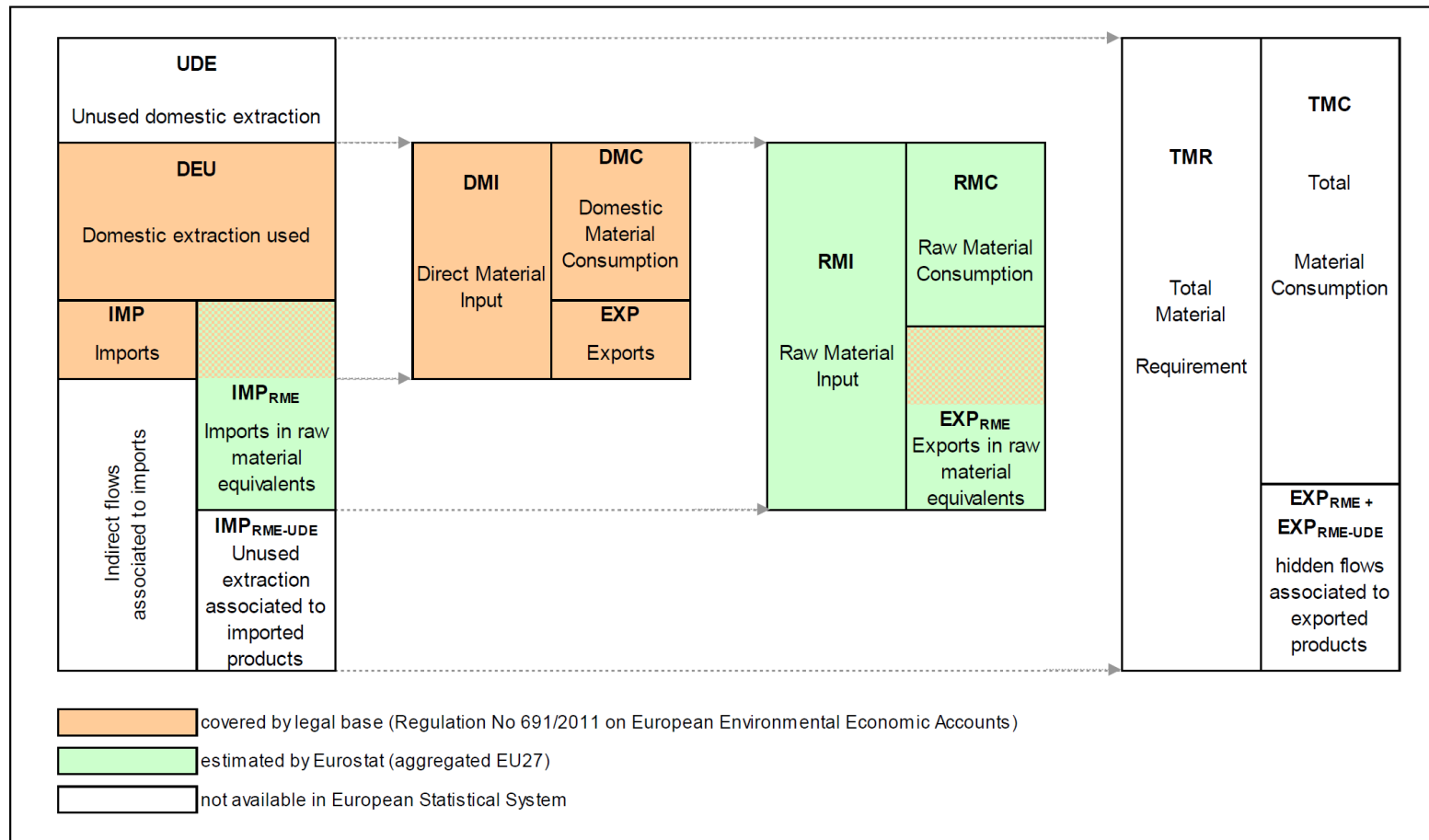

Source: Eurostat, 2013

# Direct material consumption - DMC

Domestic extraction + Imports - Exports

**Direct material consumption DMC**

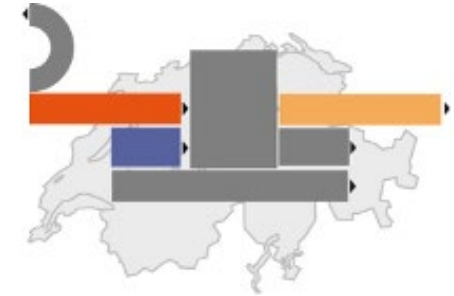

Million tonnes

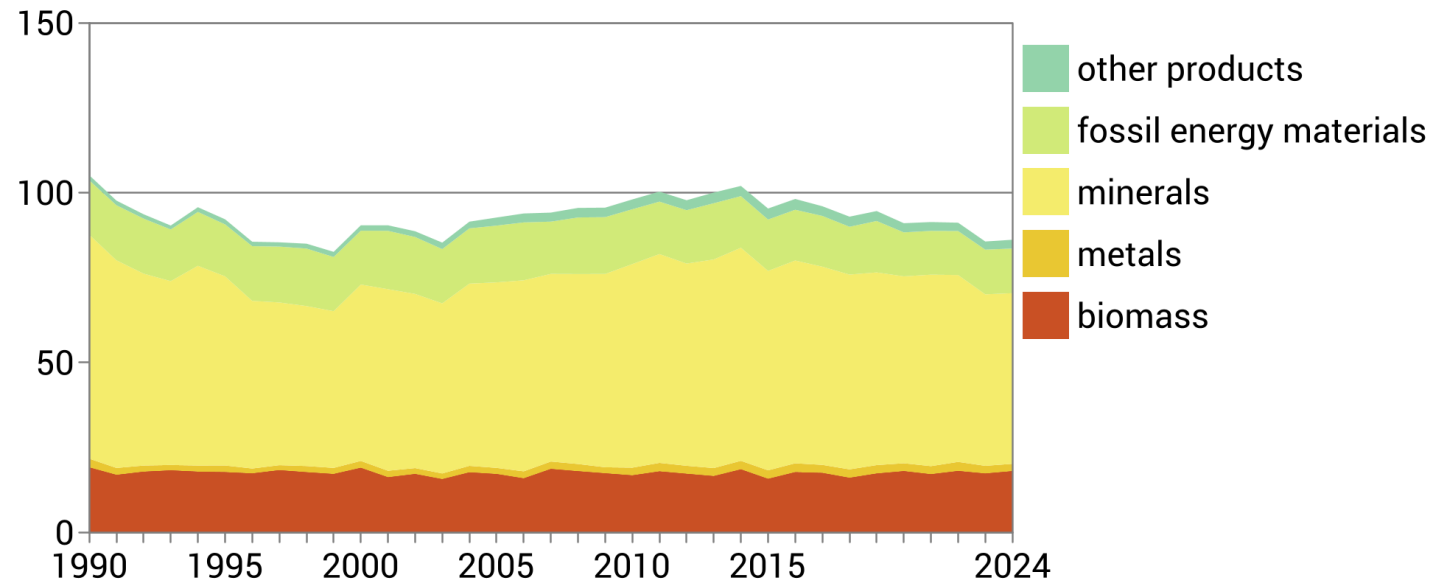

2024: estimates

Source: FSO – Environmental accounting

© FSO

- 2024: 9,5 tonnes of materials per inhabitant and year
- 2024:
  - 3% others
  - 15% fossil fuels
  - 58% minerals
  - 3% metals
  - 21% biomass

# Raw material consumption - RMC

Domestic extraction + Imports in RME – Exports in RME

## Material footprint

Raw material consumption RMC<sup>1</sup>

Million tonnes

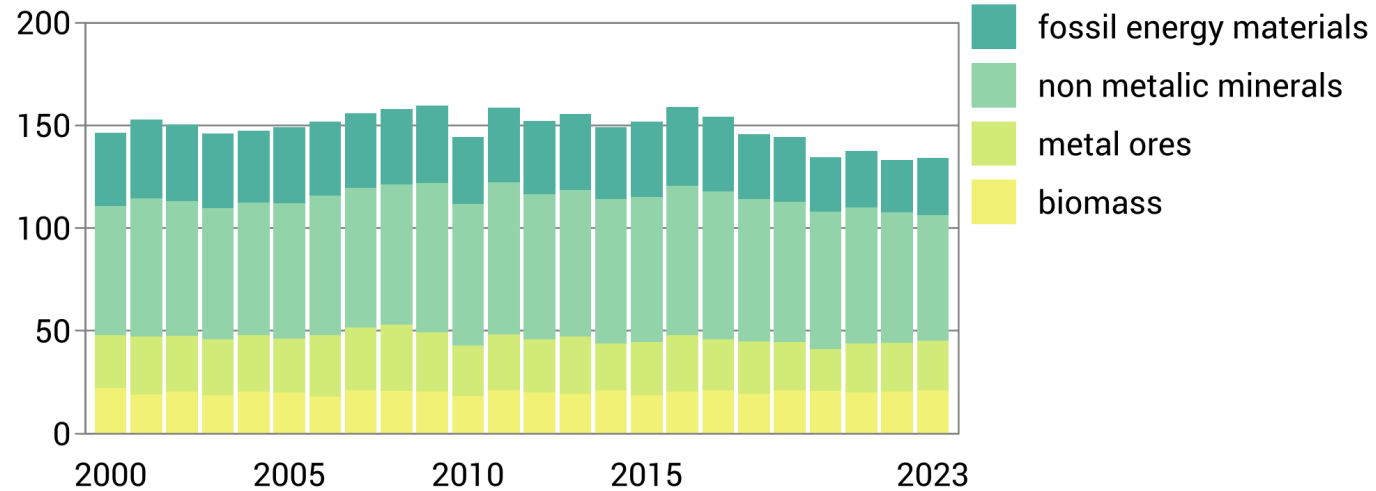

<sup>1</sup> modelling estimates

2023: provisional

Source: FSO – Environmental accounting

© FSO

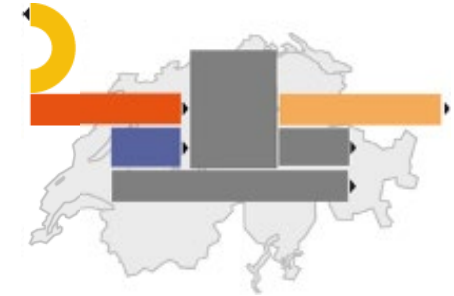

- 2023: 15,0 tonnes of materials per inhabitant and year
- 2023:
  - 16% biomass
  - 46% minerals
  - 18% metals ores
  - 21% fossil fuels

# Net additions to stock

## Net additions to stock

Million tonnes

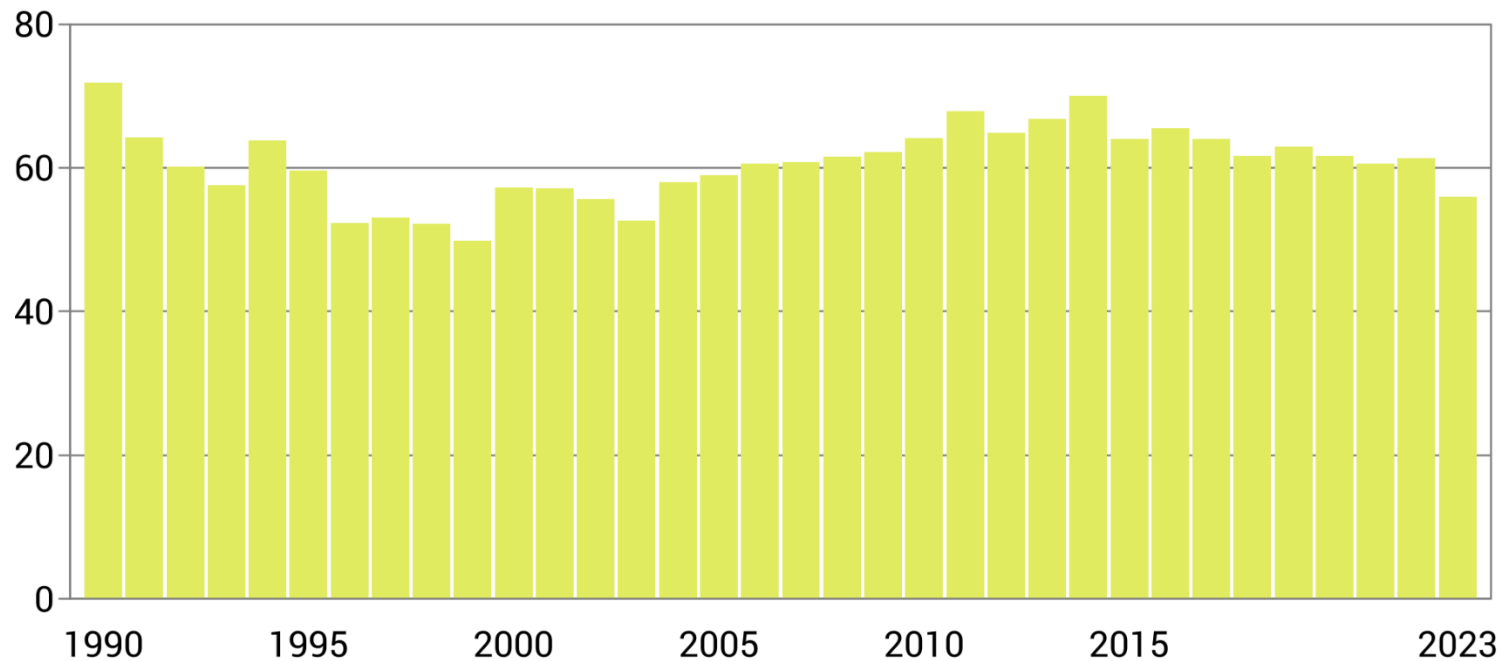

Source: FSO – Environmental accounting

© FSO

- calculated indirectly by difference (input-output)
- 2023: 6,2 tonnes of materials per inhabitant and year

# EW-MFA and the circular economy



Source: FOEN 2019

# Indicators for the EU Circular Economy Action Plan

## Circular economy monitoring framework

### 1 A-B MATERIAL CONSUMPTION

Material footprint and resource productivity

### 2 GREEN PUBLIC PROCUREMENT

Share of major public procurement that includes environmental requirements

### 3 A-F WASTE GENERATION

Total waste generation, total waste generation (excluding major mineral waste) per GDP unit, municipal waste generation, food waste, generation of packaging waste and of plastic packaging waste

### 6 A-B CONTRIBUTION OF RECYCLED MATERIALS TO RAW MATERIAL DEMAND

Secondary raw materials share of overall materials demand – for the whole economy and for specific materials

### 7 A-C TRADE IN RECYCLABLE RAW MATERIALS

Imports, exports and intra EU trade of selected recyclable raw materials



### 4 A-B OVERALL RECYCLING RATES

Recycling rate of municipal waste and of all waste except major mineral waste

### 5 A-C RECYCLING RATES FOR SPECIFIC WASTE STREAMS

Recycling rate of overall packaging waste, of plastic packaging waste and of WEEE separately collected

### 8 A-C PRIVATE INVESTMENTS, JOBS AND VALUE ADDED RELATED TO CIRCULAR ECONOMY SECTORS

Private investments, number of persons employed and gross value added related to the circular economy

### 9 INNOVATION

Patents on waste and recycling

### 10 A-B GLOBAL SUSTAINABILITY

Consumption footprint and GHG emissions from production activities

### 11 A-B RESILIENCE

Material import dependency and EU self-sufficiency for raw materials

Source: European commission 2023

# Material flow accounts and the circular economy

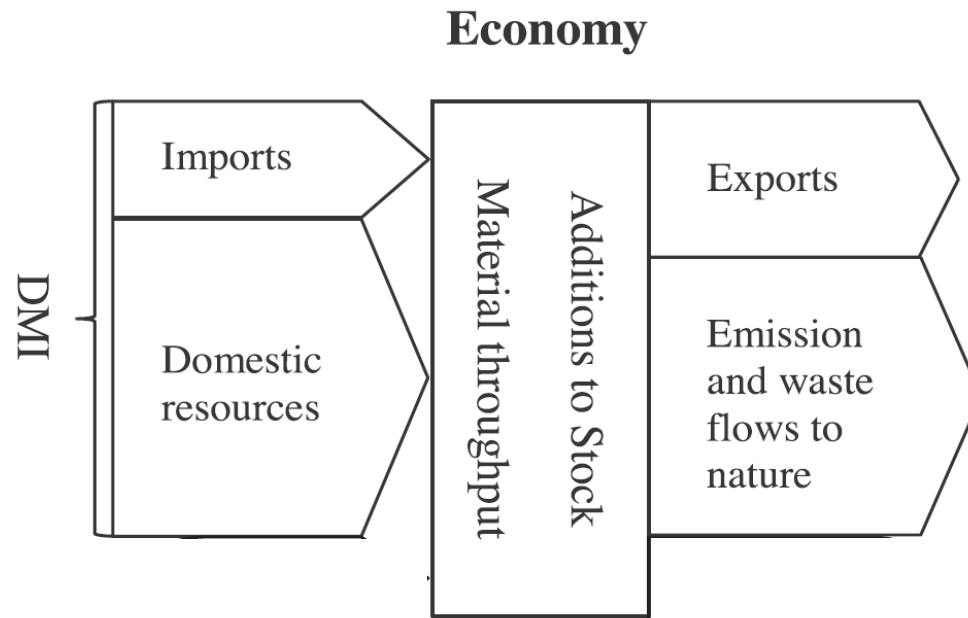

Circular material use rate

$$CMU = \frac{U}{M}$$

**CMU** cyclical material use  
**U** cyclical use of materials  
**M** overall use of materials

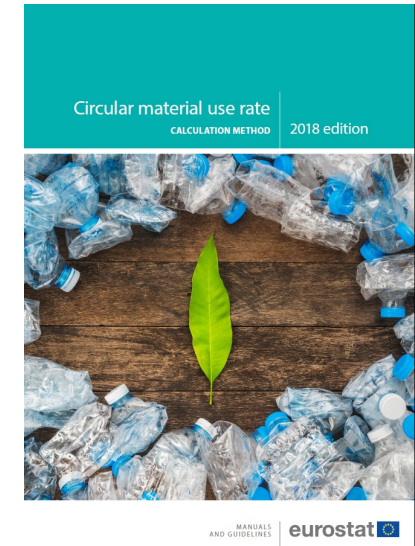

Source: Kovanda 2014, Eurostat 2018

# From theory to practice

Example: material flow analysis, glass recycling in Switzerland, 2012 (Haupt et al. 2017)

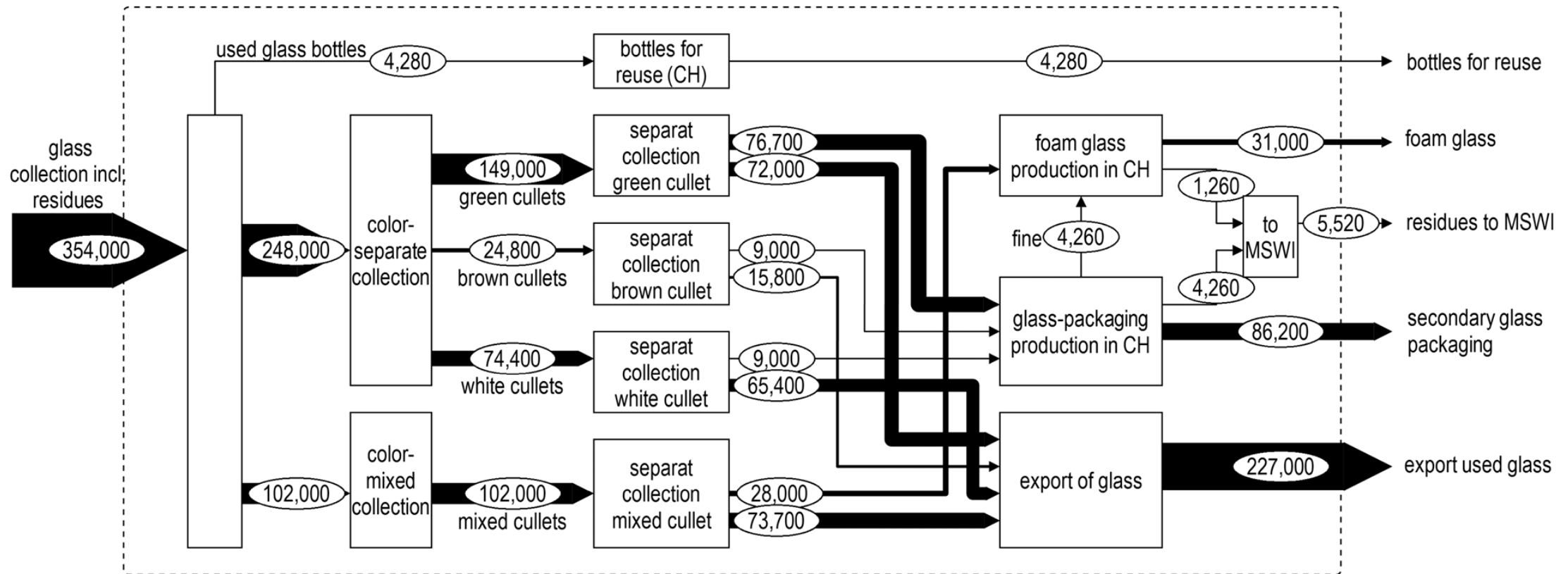

# The «pragmatic» approach of eurostat

The quantity of secondary raw materials (U) is approximated on the basis of three existing statistics:

- Material flow accounts
- Waste statistics (recovered quantities)
- Foreign trade (waste)

# The «pragmatic» approach of eurostat

RCV\_R = Recovery (excluding energy recovery and backfilling)

$IMP_w$  = imported waste for recovery

$EXP_w$  = exported waste for recovery

$$CMU = \frac{U}{DMC + U} = \frac{(RCV_R - IMP_w + EXP_w)}{DMC + (RCV_R - IMP_w + EXP_w)}$$

DMC = Domestic material consumption

CMU = Circular material use rate

Source: Eurostat 2018

# Specificities for Switzerland

In Switzerland, there are no comprehensive statistics on waste treatment according to the Eurostat approach.

The information must be gathered from the various existing statistics (municipal waste, special waste, construction waste, etc.), trying to come as close as possible to the Eurostat definitions.

# Results

## Circular material use rate<sup>1</sup>

Share of waste recovery streams in total material consumption

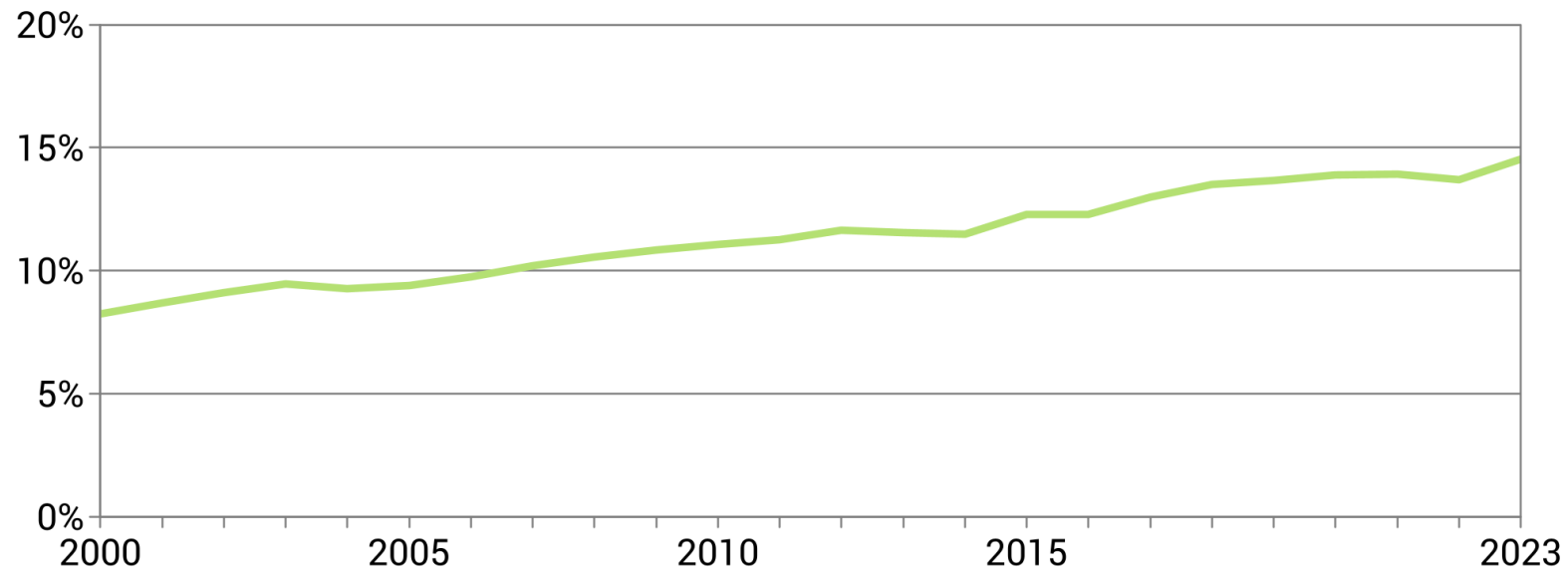

<sup>1</sup> estimates

Source: FSO – Environmental accounting

© FSO

# Results

## Circular material use<sup>1</sup>

By material categories, in thousand tonnes

G4

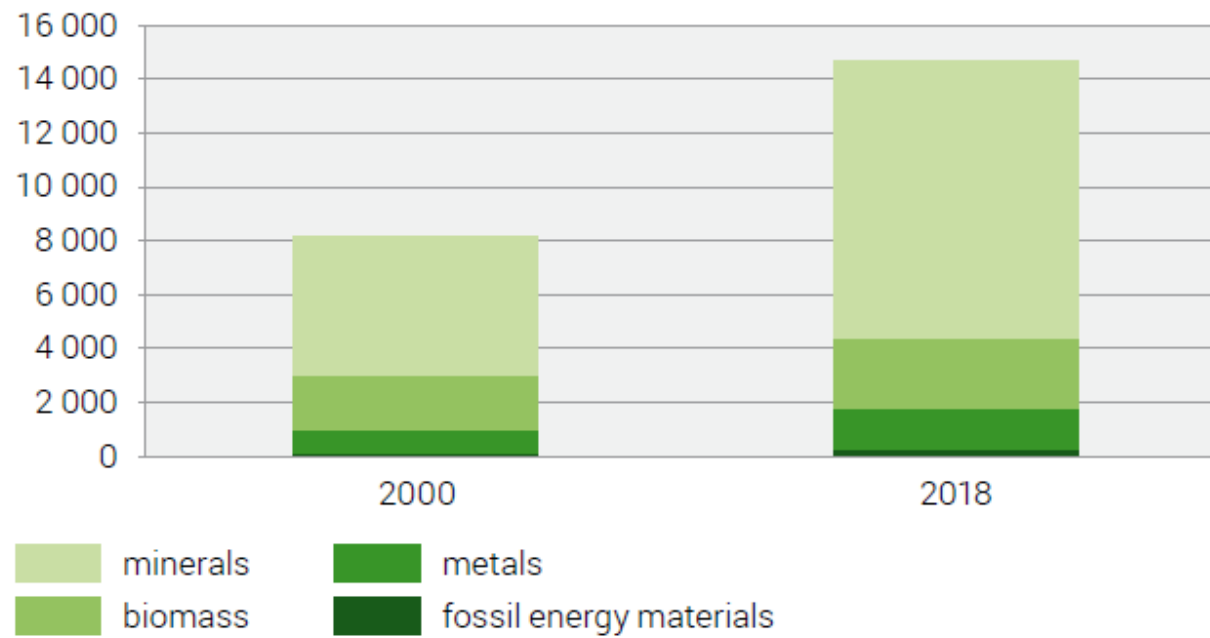

<sup>1</sup> estimates

Source: FSO – Environmental accounts

© FSO 2020

# Sankey diagram

Material flows in tonnes per person, 2023

G5

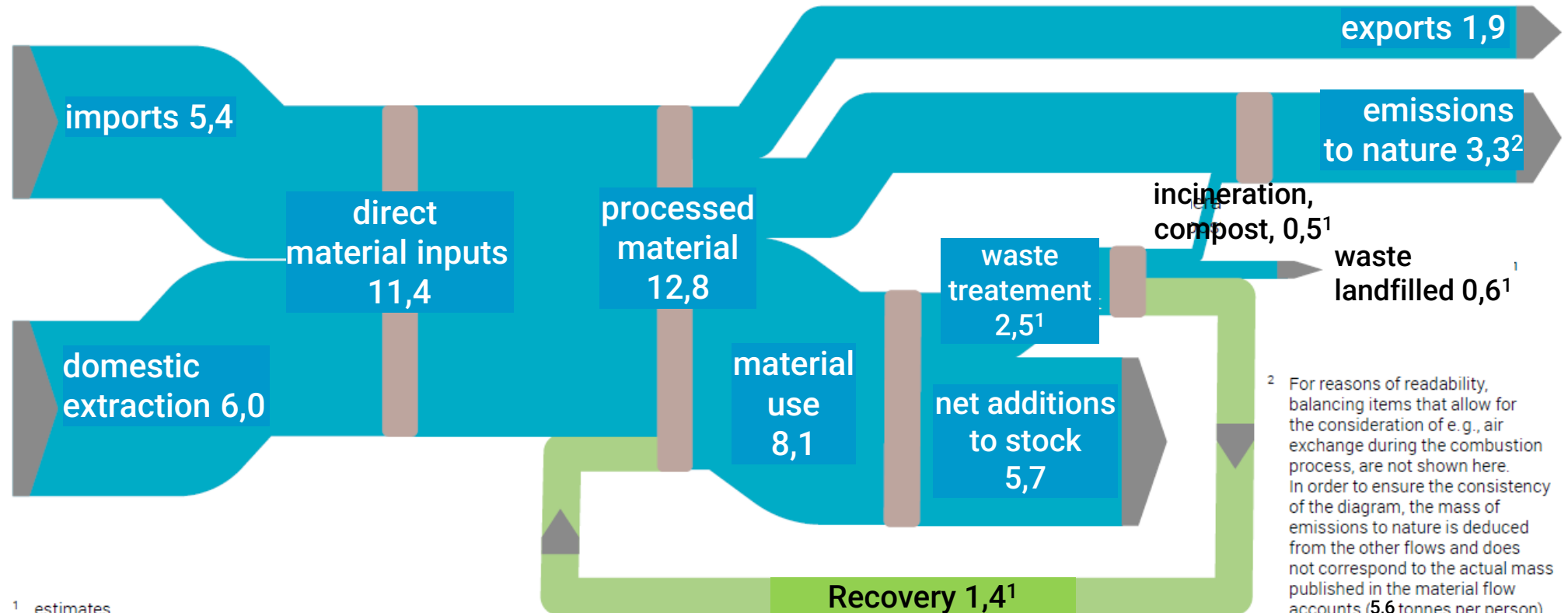

<sup>1</sup> estimates

<sup>2</sup> For reasons of readability, balancing items that allow for the consideration of e.g., air exchange during the combustion process, are not shown here. In order to ensure the consistency of the diagram, the mass of emissions to nature is deduced from the other flows and does not correspond to the actual mass published in the material flow accounts (5,6 tonnes per person).

Source: FSO – Environmental accounts

# Publications and use

## Online

**OFS:** <https://www.bfs.admin.ch/bfs/en/home/statistics/territory-environment/environmental-accounting.html>

The publication about circular economy: <https://www.bfs.admin.ch/bfs/en/home/statistics/territory-environment/environmental-accounting.assetdetail.13487975.html>

**Eurostat:** <https://ec.europa.eu/eurostat/web/environment/overview>

## Data

Office fédéral de la statistique  
Swiss Stats Explorer

Swiss Stats Explorer

Retour aux résultats de recherche

Affinez votre sélection de données:

PÉRIODE: 5

CATÉGORIE DE MATIÈRES: 7

FLUX: 3

Chercher dans les 16 éléments

- Appareils directs de matières
- Consommation intérieure de matières
- Apports de matières premières
- Consommation intérieure de matières premières – e...
- Balance commerciale physique
- Emissions dans la nature
- Éléments d'équilibrage du bilan en entrées
- Éléments d'équilibrage du bilan en sorties
- Addition nette de stock

UNITÉ DE MESURE: 2

210 points de données sélectionnés

Catégorie de matières: x Catégorie de r

Matières/vecteurs énergétiques fossiles

Vue d'ensemble Tableau Graphique

Comptes de flux de matières - I

Fréquence d'observation: Annuel

Unité de mesure	Catégorie de
Flux: Consommation intérieure de matières	
Milliers de tonnes	Biomasse
Milliers de tonnes	Minerais
Milliers de tonnes	Minerais
Milliers de tonnes	Matières/
Milliers de tonnes	Autres pr
Milliers de tonnes	Déchets
Tonnes par habitant *	Catégorie de
Tonnes par habitant *	Biomasse
Tonnes par habitant *	Minerais
Tonnes par habitant *	Minerais
Tonnes par habitant *	Matières/
Tonnes par habitant *	Autres pr

## Print

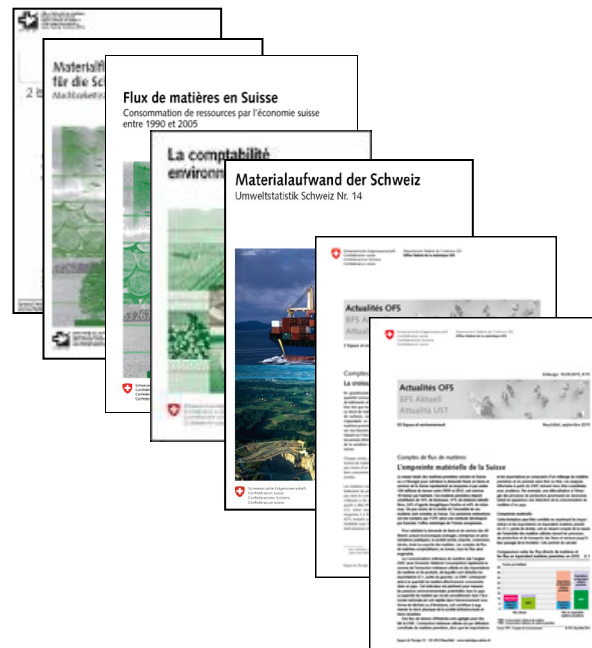

## Indicators



### Indicateurs de l'environnement

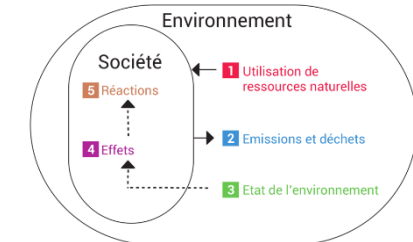

Source: OFS

© OFS, 2016





# Thanks for your attention !

